

THREAD SIZE	CODE	LENGHT										GRIP RANGE	DRILL	SPACE MIN	ød	ØA	H	e	k	
M3x0,5	04M03xxSTC		8	10	11	14	16	18	20	22	25	1,0	4,22	6	4,19	4,0	4,8	0,4	0,4	
3,5M3x0,5	0435M03xxSTC	6	8	10	11	14	16	18	20	22	25	1,0	5,41	6,8	5,38	4,7	6,4	0,4	0,5	
M3,5x0,6	04M35xxSTC	6	8	10	11	14	16	18	20	22	25	1,0	5,41	6,8	5,38	4,7	6,4	0,4	0,5	
M4x0,7	04M04xxSTC		8	10	11	14	16	18	20	22	25	1,3	7,14	8	7,11	6,4	8,0	0,6	0,6	
M5x0,8	04M05xxSTC		8	10	11	14	16	18	20	22	25	1,3	7,14	8	7,11	6,4	8,0	0,6	0,6	
	f min	3,2	4	5	6,5	9,5														

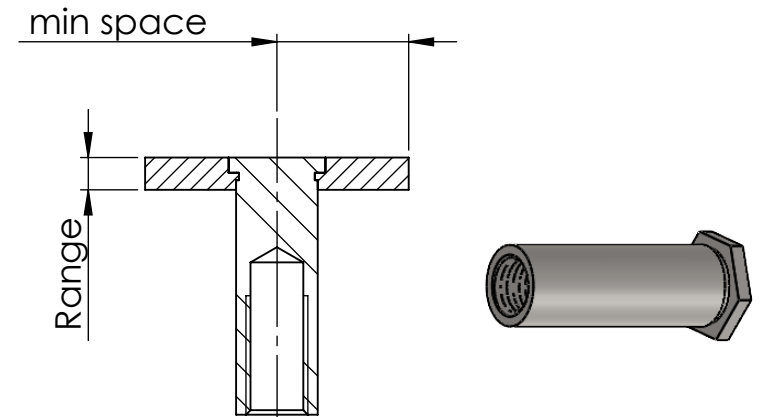
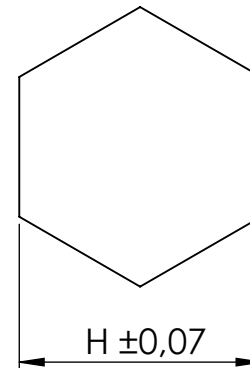
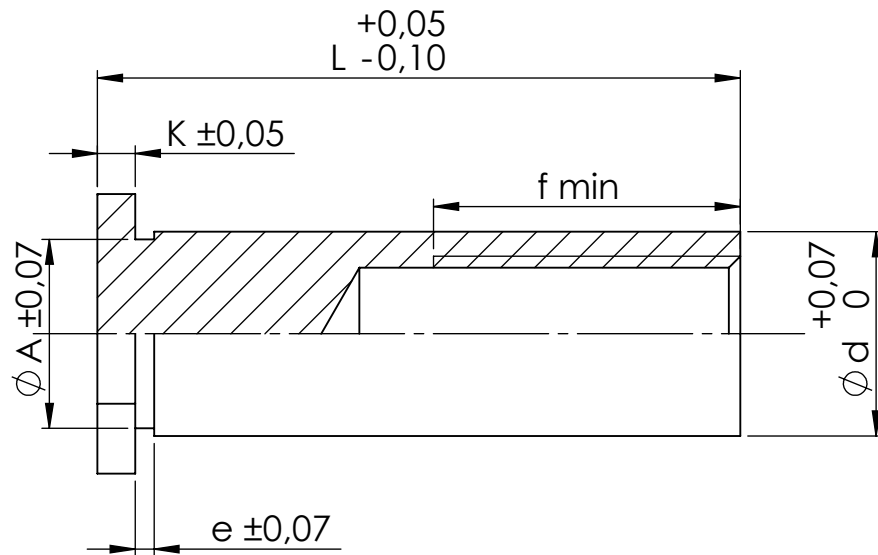

Este plano es propiedad de Smartfix S.L. todos los derechos reservados/ This drawing is the property of Smartfix S.L. all rights reserved

FECHA DATE		NOMBRE NAME		DENOMINACIÓN DESCRIPTION		ESPECIFICACIONES GENERALES GENERAL SPECIFICATIONS					
DIBUJADO DRAWN BY		20/10/2021		J. J. Ciordia		Separador rosca ciega/ Blind Threaded standoff		TOLERANCIAS TOLERANCES		Según plano/ According drawing	
		MATERIAL		Acero 10B21/ Steel 10B21		UNIDADES UNITS		mm			
		ACABADO FINISHED		Cincado / Zinc plated				A4			
REFERENCIA: REFERENCE		04-STC									

THREAD SIZE	CODE	LENGHT										GRIP RANGE	DRILL	SPACE MIN	ød	øA	H	e	k	
M3x0,5	04M03xxA2C		8	10	11	14	16	18	20	22	25	1,0	4,22	6	4,19	4,0	4,8	0,4	0,4	
3,5M3x0,5	0435M03xxA2C	6	8	10	11	14	16	18	20	22	25	1,0	5,41	6,8	5,38	4,7	6,4	0,4	0,5	
M3,5x0,6	04M35xxA2C	6	8	10	11	14	16	18	20	22	25	1,0	5,41	6,8	5,38	4,7	6,4	0,4	0,5	
M4x0,7	04M04xxA2C		8	10	11	14	16	18	20	22	25	1,3	7,14	8	7,11	6,4	8,0	0,6	0,6	
M5x0,8	04M05xxA2C		8	10	11	14	16	18	20	22	25	1,3	7,14	8	7,11	6,4	8,0	0,6	0,6	
	f min	3,2	4	5	6,5	9,5														

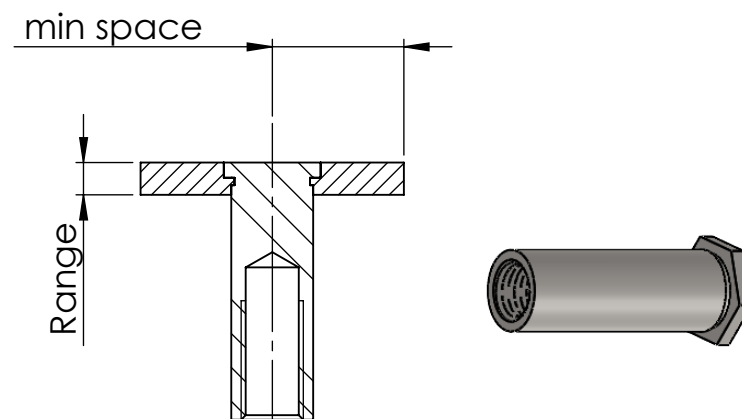
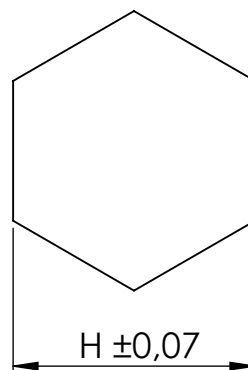
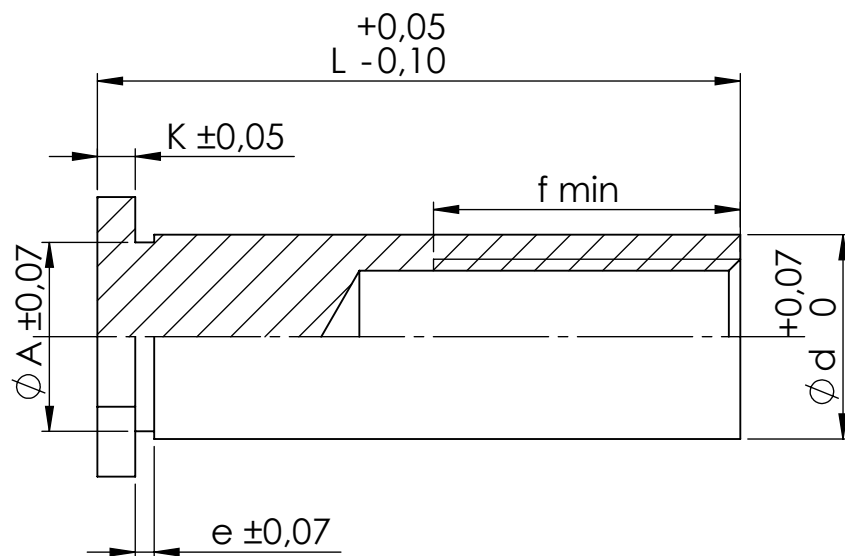

Este plano es propiedad de Smartfix S.L. todos los derechos reservados/ This drawing is the property of Smartfix S.L. all rights reserved

FECHA DATE		NOMBRE NAME		DENOMINACIÓN DESCRIPTION		ESPECIFICACIONES GENERALES GENERAL SPECIFICATIONS					
DIBUJADO DRAWN BY		20/10/2021		J. J. Ciordia		Separador rosca ciega/ Blind Threaded standoff		TOLERANCIAS TOLERANCES		Según plano/ According drawing	
		MATERIAL MATERIAL		Acero inox / Stainless steel 303		UNIDADES UNITS		mm			
		ACABADO FINISHED		Pasivado / Pasivated ASTM A380		REFERENCIA: REFERENCE		04-A2C			
								A4			