

CODE NO.	THREAD	GRIP RANGE	DRILL	d	D	K	L	I	C	S	GROV	SERR.	Lf	TENSILE(KN)	TORQUE (Nm)
01041STCKNCB	M4-P0,7	1,5-3,5	Ø6,0	Ø5,9	Ø8,5	1,50	17,50	4,80	6,00	5,64	24T	30T	13,00	6,80	3,00
01051STCKNCB	M5-P0,8	1,5-4,0	Ø7,0	Ø6,9	Ø9,5	1,50	20,50	5,70	7,00	6,64	24T	36T	14,50	10,00	6,00
01061STCKNCB	M6-P1,0	1,5-4,5	Ø9,0	Ø8,9	Ø11,5	1,50	23,50	7,60	7,70	8,64	30T	36T	16,50	15,00	10,00
01081STCKNCB	M8-P1,25	1,5-4,5	Ø11,0	Ø10,9	Ø13,5	1,50	28,00	9,50	8,20	10,64	36T	36T	21,00	27,00	24,00
01101STCKNCB	M10-P1,5	1,5-4,5	Ø13,0	Ø12,9	Ø15,5	1,50	36,00	11,20	8,70	12,61	40T	36T	28,50	37,00	48,00

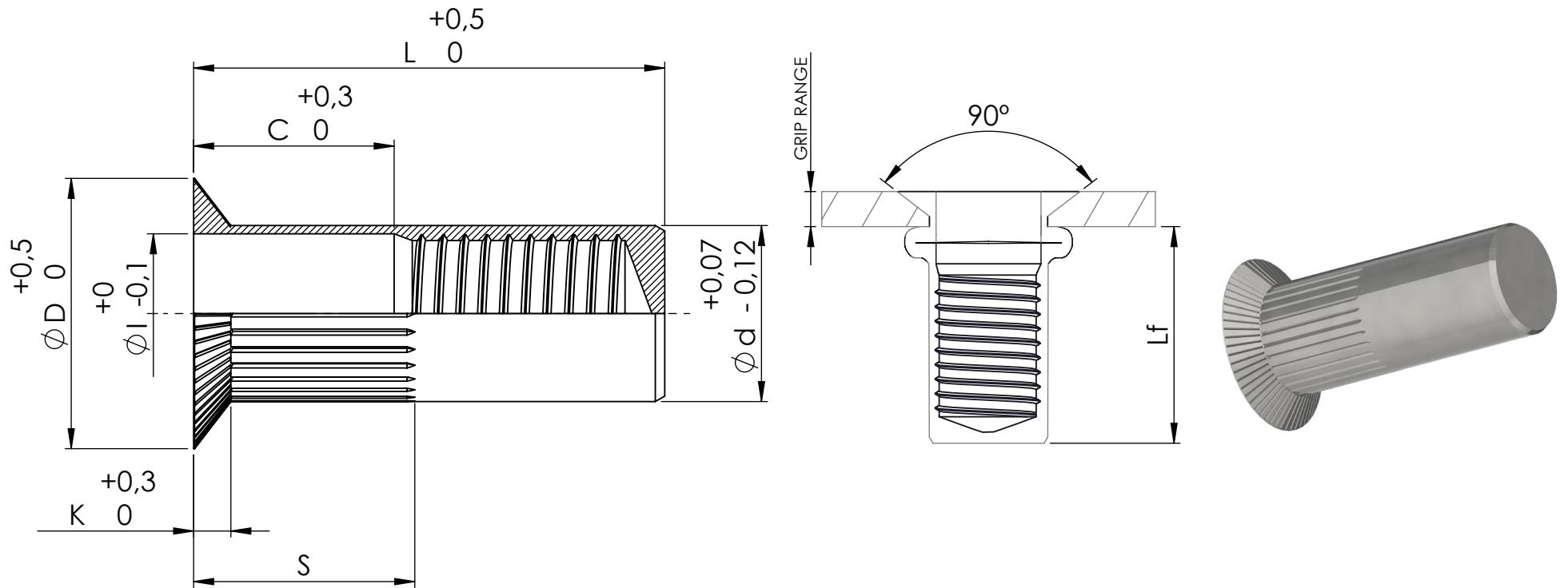

Este plano es propiedad de Smartfix S.L. todos los derechos reservados/ This drawing is property of Smartfix S.L. all rights reserved

DIBUJADO / DRAWN BY FECHA / DATE	J.SANZ 15/11/2021	DENOMINACIÓN DESCRIPTION	TIJERA REM. ACERO C. AVELLANADA RAN. CERRADA / RIVET NUT COUNTERSUNK HEAD KNURLED STEEL BODY CLOSED-END	ESPECIFICACIONES GENERALES GENERAL SPECIFICATIONS
REVISIÓN / REVISION FECHA / DATE	Rev. 0 15/11/2021	MATERIAL MATERIAL	ACERO 1008 / STEEL 1008	TOLERANCIAS TOLERANCES
		ACABADO FINISHED	CINCADO / ZINC PLATED	Según plano/ According drawing
		REFERENCIA REFERENCE	01-STCKNCB	UNIDADES UNITS
				mm
				⊕
				A4

CODE NO.	THREAD	GRIP RANGE	DRILL	d	D	K	L	I	C	S	GROV	SERR.	Lf	TENSILE(KN)	TORQUE (Nm)
01041A2CKNCB	M4-P0,7	1,5-3,5	Ø6,0	Ø5,9	Ø8,5	1,50	17,50	4,80	6,00	5,64	24T	30T	13,00	6,80	3,00
01051A2CKNCB	M5-P0,8	1,5-4,0	Ø7,0	Ø6,9	Ø9,5	1,50	20,50	5,70	7,00	6,64	24T	36T	14,50	10,00	6,00
01061A2CKNCB	M6-P1,0	1,5-4,5	Ø9,0	Ø8,9	Ø11,5	1,50	23,50	7,60	7,70	8,64	30T	36T	16,50	15,00	10,00
01081A2CKNCB	M8-P1,25	1,5-4,5	Ø11,0	Ø10,9	Ø13,5	1,50	28,00	9,50	8,20	10,64	36T	36T	21,00	27,00	24,00
01101A2CKNCB	M10-P1,5	1,5-4,5	Ø13,0	Ø12,9	Ø15,5	1,50	36,00	11,20	8,70	12,61	40T	36T	28,50	37,00	48,00

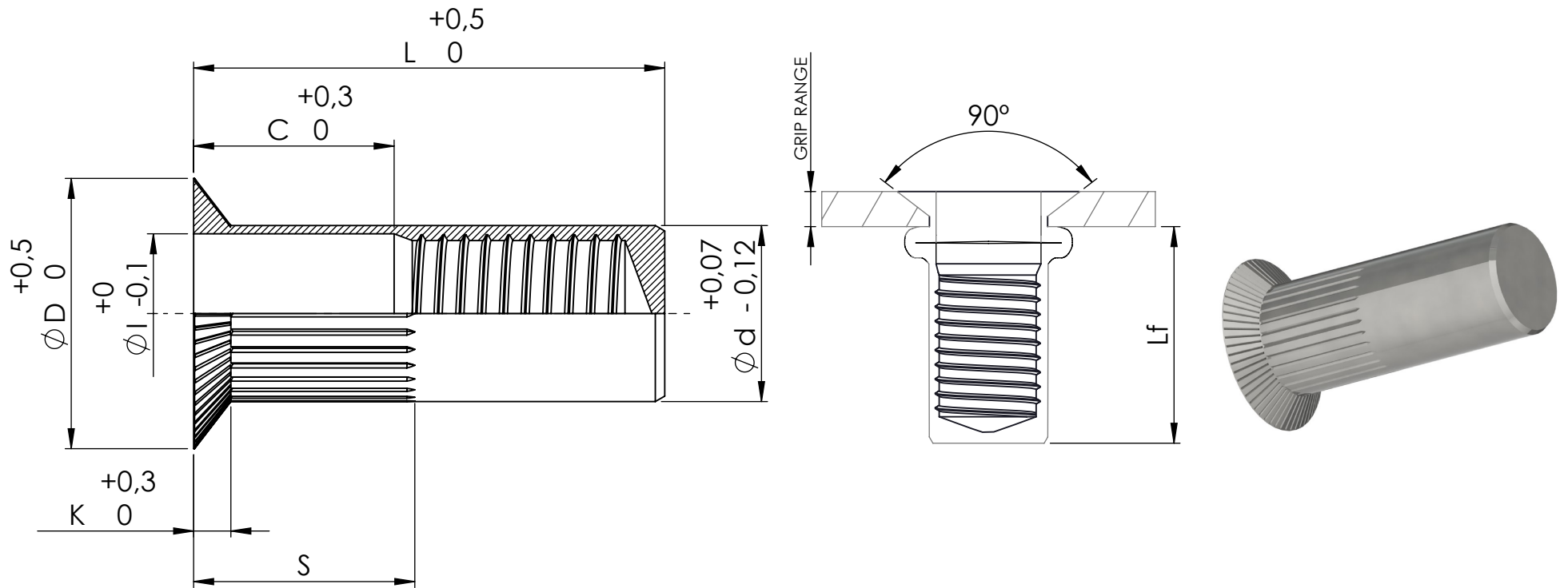

Este plano es propiedad de Smartfix S.L. todos los derechos reservados/ This drawing is property of Smartfix S.L. all rights reserved

DIBUJADO / DRAWN BY FECHA / DATE	J.SANZ 15/11/2021	DENOMINACIÓN DESCRIPTION	TIJERA REM. INOX A2 C. AVELLANADA RAN. CERRADA / RIVET NUT COUNTERSUNK HEAD KNURLED S. STEEL BODY CLOSED-END	ESPECIFICACIONES GENERALES GENERAL SPECIFICATIONS
REVISIÓN / REVISION FECHA / DATE	Rev. 0 15/11/2021	MATERIAL MATERIAL	INOX A2 / STAINLESS STEEL A2	TOLERANCIAS TOLERANCES
		ACABADO FINISHED	PASIVADO / BRIGHT	Según plano/ According drawing
		REFERENCIA REFERENCE	01-A2CKNCB	UNIDADES UNITS
				mm
				⊕
				A4