

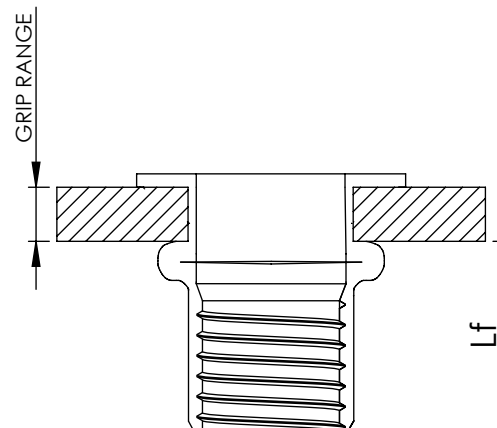

CODE NO.	THREAD	GRIP RANGE	DRILL	d	D	K	L	C	Lf
01051STFTROB	M5-P0,8	0,5-4,4	Ø8,10	Ø7,00	Ø12,70	1,1	$\begin{matrix} +0 \\ 20 - 0,2 \end{matrix}$	13,20	9-11
01061STFTROB	M6-P1,0	0,5-7,1	Ø9,90	Ø9,00	Ø15,90	1,5	$\begin{matrix} +0,4 \\ 26 - 0 \end{matrix}$	18,2	10-12
01081STFTROB	M8-1,25	0,5-7,1	Ø12,50	Ø11,00	Ø19,00	1,60	$\begin{matrix} +0,2 \\ 30 - 1,2 \end{matrix}$	19,60	12-14

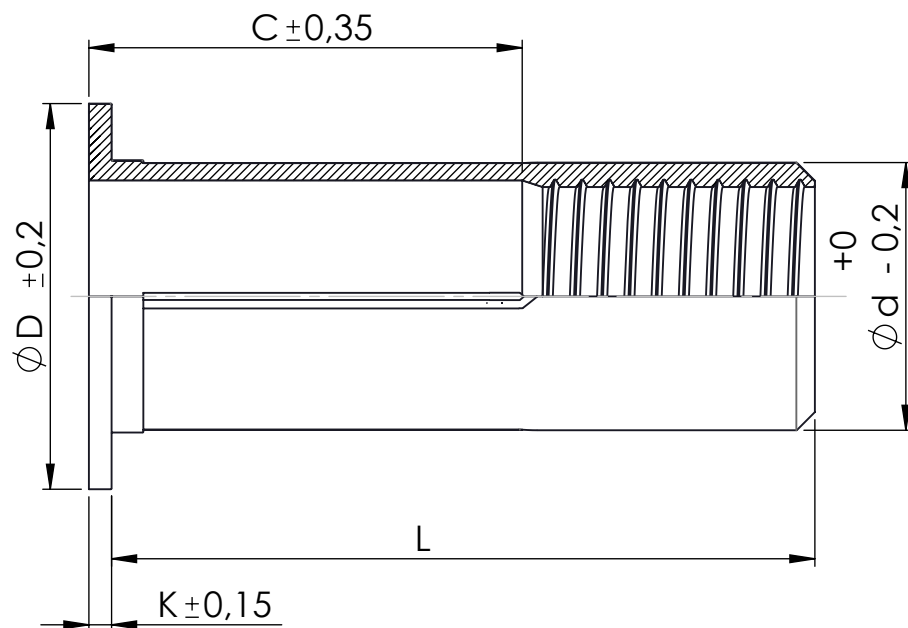

Este plano es propiedad de Smartfix S.L. todos los derechos reservados/ This drawing is property of Smartfix S.L. all rights reserved

DIBUJADO / DRAWN BY FECHA / DATE	J.SANZ 15/11/2021	DENOMINACIÓN / DESCRIPTION	TUERCA REM. ACERO C/ANCHA TREFOL ABIERTA / RIVET NUT FLAT HEAD TRIFORM STEEL BODY OPEN-END	ESPECIFICACIONES GENERALES / GENERAL SPECIFICATIONS
REVISIÓN / REVISION FECHA / DATE	Rev. 0 15/11/2021	MATERIAL	ACERO 1008 / STEEL 1008	TOLERANCIAS / TOLERANCES Según plano / According drawing
 TECNOLOGÍA & INNOVACIÓN		ACABADO / FINISHED	CINCADO / ZINC PLATED	UNIDADES / UNITS mm
		REFERENCIA / REFERENCE	01-STFTROB	 A4